

PRESSURE AND TEMPERATURE DEPENDENCE OF THE EXCESS ENTHALPY  
OF ALKYLCHLORIDE/ALKANE MIXTURES

A. KOHL AND A. HEINTZ

Physikalisch-Chemisches Institut der Universität  
Im Neuenheimer Feld 253, D-6900 Heidelberg

ABSTRACT

There exist only few experimental data of the excess enthalpy of liquid mixtures at high pressure in literature. In this work some recent experimental results of the excess enthalpy  $H^E$  for alkylchloride/alkane mixtures are reported measured at different pressures and temperatures by using a high pressure flow calorimeter.  $H^E$  shows a relatively weak dependence on pressure compared with other polar/unpolar systems such as alcohol/alkane mixtures (ref.1).

EXPERIMENTAL PROCEDURE

Excess enthalpies of the 4 binary mixtures butylchloride + hexane, butylchloride + nonane, dècylchloride + hexane, and decylchloride + nonane have been measured at 293 and 313 K and different pressures up to 500 bar using an isothermal flow calorimeter schematically shown in Fig. 1.

Two HPLC pumps ( $P_1$  and  $P_2$ ) filled with liquids from the reservoirs  $RV_1$  and  $RV_2$  deliver the two liquid components with constant and accurately known volume speeds into the calorimeter. The components are mixed at point M in the internal waterbath of the calorimeter. While flowing through a coiled mixing tubing the mixture exchanges the heat of mixing with the surrounding internal waterbath of the calorimetric reaction vessel which is stirred by stirrer  $R_i$ .

Constant pressure is maintained at continuous flow rates by using a back pressure regulator valve DRV. The pressure under which the mixing process takes place is measured with the manometer MA. The heat of mixing continuously exchanged with the internal water bath is determined in the following way: a Peltier cooler PK and a heater RH able to work with variable heating power are placed in the bottom of the calorimetric reaction vessel containing the internal waterbath.

PK absorbs heat from the internal waterbath at a constant rate. RH compensates for the cooling power of PK. The heating power of RH is controlled by the electronic control circuit  $ERK_1$  so that the temperature  $T_1$  in the internal waterbath monitored by a thermistor MTH is always identical with the reference temperature  $T_e$  in the external waterbath.  $T_e$  is kept at a very constant value by the electronic control circuit  $ERK_e$ .

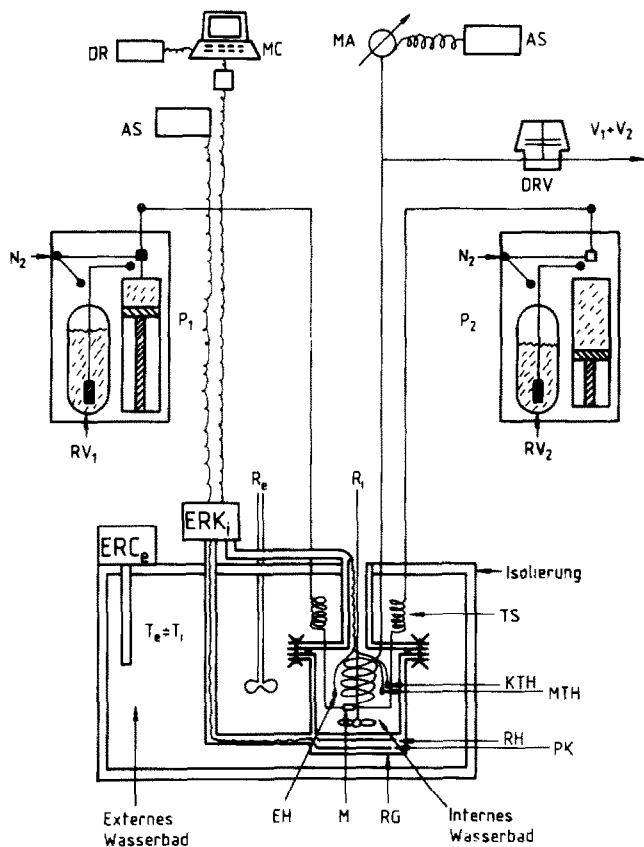

Fig. 1. Schematic diagram of the high pressure flow calorimeter. (The essential symbols are described in the text.)

Additional cooling or heating sources caused by endothermic or exothermic mixing processes in the coiled tubing are compensated by a corresponding change of the heating power of RH. The heating rate of RH is delivered by heat pulses (0 - 24 kHz) and can be registered digitally by a microcomputer MC. Calibration of the compensating heating power is performed by a calibration heater EH which simulates an exothermic process with accurately known heating power.

The difference of the heating power delivered by RH during a mixing process and without mixing process is denoted  $\Delta\dot{Q}$ .  $\Delta\dot{Q}$  is connected with the molar enthalpy of mixing  $H^E$  by eq.1 :

$$H^E = \frac{\Delta\dot{Q}}{\frac{\rho_1}{M_1}v_1 + \frac{\rho_2}{M_2}v_2} \quad (1)$$

whereas  $M_1$  and  $M_2$  are the molar masses,  $\rho_1$  and  $\rho_2$  are the densities, and  $v_1$  and  $v_2$  are the volume speeds of the two components mixed in the calorimeter.

The molfraction  $x_1 = 1 - x_2$  associated with  $H^E$  in eq.1 is defined by eq.2:

$$x_1 = \frac{\Delta\dot{Q}}{\frac{\rho_1}{M_1}v_1 + \frac{\rho_2}{M_2}v_2} \quad (2)$$

Experimental data of  $H^E$  at different molefractions are obtained working with different ratios of  $v_1$  and  $v_2$ .

## RESULTS AND DISCUSSION

Fig.2 shows the results for the 4 binary systems at 1 bar and 293 K.  $H^E$  data obtained for the butylchloride mixtures are distinctly higher than those obtained for the decylchloride mixtures.

This result can be explained by the fact that the number density of polar  $\text{Cl-CH}_2$  - groups is higher in butylchloride than in decylchloride. Mixing butylchloride with an unpolar alkane (hexane or nonane) has a stronger dilution effect on the  $\text{Cl-CH}_2$  - groups than mixing decylchloride with alkane at about the same molar concentration.

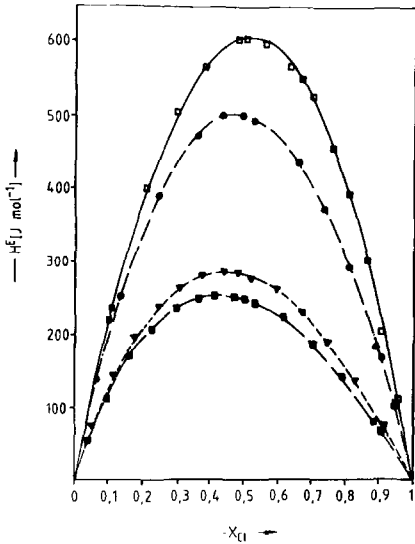

Fig. 2. Experimental results of  $H^E$  at 1 bar and 293 K.  
 butylchloride+nonane: ———□———  
 butylchloride+hexane: —●— · —  
 decylchloride+nonane: ———▼———  
 decylchloride+hexane: ———■———

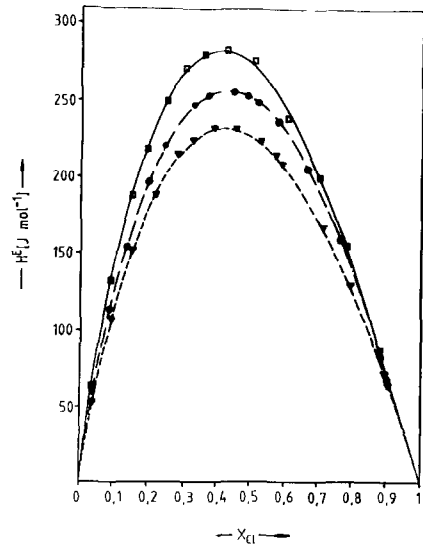

Fig. 3. Experimental results of  $H^E$  at different pressures and temperatures.  
 decylchloride+hexane at 1 bar and 293 K: —●— · —  
 decylchloride+hexane at 500 bar and 293 K: ———□———  
 decylchloride+hexane at 1 bar and 313 K: ———▼———  
 decylchloride+hexane at 500 bar and 313 K: ———■———

A larger amount of strongly attractive intermolecular energy contacts of  $\text{Cl-CH}_2$  - groups are broken upon mixing associated with endothermic  $H^E$  in case of butylchloride mixtures than in case of decylchloride mixtures.

It is striking that  $H^E$  values are lower for alkylchloride + hexane mixtures than for alkylchloride + nonane mixtures.

The concept of the correlation of molecular order (CMO) (see ref.2-4) observed in liquid alkanes and alkane mixtures offers a possible explanation for this effect. The CMO concept shows that  $H^E$  is more endothermic for mixtures of a globular molecule mixed with nonane than mixed with the smaller chain molecule hexane. If we assume that the alkylchlorides play a similar role as the globular molecule the results presented in Fig. 2 can be interpreted by the CMO model: nonane has a higher degree of CMO than hexane. Energetically more stabilized intermolecular contacts have to be destroyed in nonane than in hexane upon mixing.

Fig.3 shows  $H^E$  data for decylchloride + hexane as selected examples for the results obtained at higher pressure and higher temperature.  $H^E$  increases by ca. 25 Joule/mol in the maximum at 293 K when the pressure rises from 1 to 500 bar.  $H^E$  decreases at 1 bar with increasing temperature. This behavior is analog to the results observed for cyclohexane + alkane mixtures (see ref. 2+3). Similar results are obtained for the system decylchloride + nonane (not shown in this work).

$H^E$  of the butylchloride systems, however, shows only a weak decrease with temperature and no significant dependence on pressure.

A more detailed report on results of alkylchloride systems including experimental excess volumes and theoretical calculations will be published in the near future (see ref.5).

## REFERENCES

- 1 A. Heintz, Ber. Bunseng. Phys. Chem. 85, 632-635 (1981)
- 2 A. Heintz and R. N. Lichtenthaler, Ber. Bunseng. Phys. Chem. 81, 921-925 (1977)
- 3 A. Heintz and R. N. Lichtenthaler, Ber. Bunseng. Phys. Chem. a.) 84, 728-732 (1980) and b.) 84, 890-895 (1980)
- 4 A. Heintz and R. N. Lichtenthaler, Angew. Chemie Int. Ed. 21, 184-197 (1982)
- 5 J. Hauser, A. Kohl and A. Heintz, Ber. Bunseng. Phys. Chem. in preparation